

# Technical solutions in barbecues

---

DEKTON MANUAL

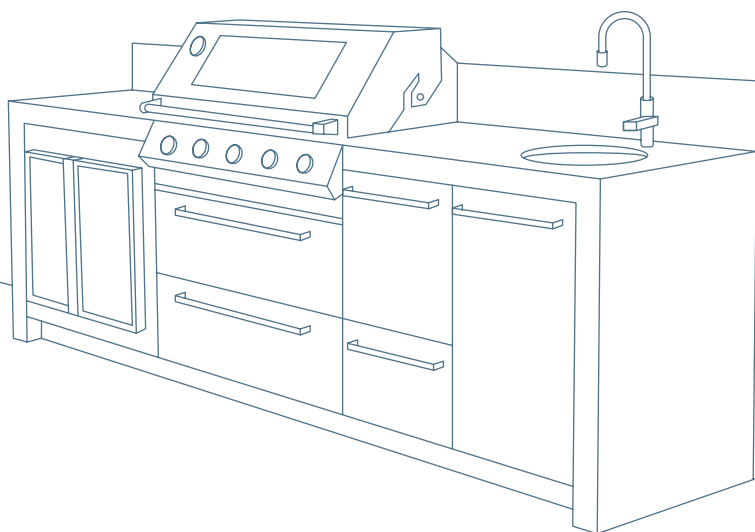

A product designed by **COSENTINO**





# INDEX

## **BASIC CONCEPTS ABOUT EXTREME HEAT**

---

### **BARBECUE TIPOLOGIES**

---

Classification according to the form in which heat is generated

---

Classification according to the insulation measures incorporated

---

### **POSSIBILITES OF THE USE OF DEKTON® AROUND THE BARBECUE**

---

Traditional barbecue

---

Prefabricated barbecue

---

### **ASPECTS TO BE CONSIDERED**

---

Thermal aspects

---

Other aspects on which the barbecue can influence

---

### **PRACTICAL CASES**

---

1<sup>st</sup> CASE: Barbecue embedded in an opening without enough space to dilate

---

2<sup>nd</sup> CASE: Barbecue on a countertop without taking into account radiant effect of burning coals

---

3<sup>rd</sup> CASE: Barbecue with interior cladding exposed to extreme conditions impossible to control

---

4<sup>th</sup> CASE: Barbecue placed badly in the middle of the cut-out and incorrect support

---

5<sup>th</sup> CASE: Barbecue supported over insufficient surface and exposed to the radiant effect of burning coals

---

### **ANNEX I: TYPICAL INSTALLATION OF A PREFABRICATED BARBECUE ON A CONSTRUCTED FURNITURE COVERED WITH DEKTON®**

---

### **ANNEX II: TECHNICAL DATASHEET TYPE OF A PREFABRICATED BARBECUE AND INCLUDED THERMAL ASPECTS**

---

# 1. BASIC CONCEPTS ABOUT EXTREME HEAT

## 1.1. DEKTON® PARAMETERS ESPECIALLY RELEVANT FOR THIS APPLICATION:

- Maximum temperature: 300 °C.
- Thermal linear dilation: between 5,1 and 6,5.  $10^{-6} \cdot ^\circ\text{C}^{-1}$  (UNE EN ISO 10545-8)
- Flexural and bending strength: > 59 N/mm<sup>2</sup> (UNE EN ISO 10545-4)

## 1.2. FORMS OF HEAT TRANSFER:

- Heat conduction (Heat transmitted through direct contact between objects): Avoid direct contact with heat sources (i.e. hot coals) and metal parts exceeding the maximum temperature (i.e. electrical resistances).
- Heat radiation (Heat transmitted between objects without any contact between them): Avoid that effect when the transmitter exceed the maximum temperature (i.e. inside cladding or under a traditional barbecue).
- Heat convection (Heat transfer between objects trough the movement of a fluid- gas or liquid-): Facilitate the circulation of air in contact with very hot parts of barbecue, to avoid a continuous and progressive heating because of the lack of ventilation (i.e. inside covered blind furniture, without grille).
- Direct flame: Avoid direct contact with flame (i.e. in fronts behind traditional barbecues in which an obstacle can project the flame against the surface).

## 1.3. PHENOMENA RELATED WITH EXTREME HEAT:

- Take always into account how the material expands when subjected to abrupt changes in temperature (i.e. metal structure of the barbecue) to avoid tensions because of lack of planning of the space for that expansion.

## 2. BARBECUE TIPOLOGIES

### 2.1. CLASSIFICATION ACCORDING TO THE FORM IN WHICH HEAT IS GENERATED

- **Charcoal or firewood barbecues:** traditional. Managed temperatures can be very high (more than 500°C). They are very dirty, sparks can escape at any time.

- **Gas barbecues:** with integrated gas bottles. Temperature can be adjusted and controlled. 250-300°C. Heat of the flame and the heat achieved by the metal conduction where the gas moves has to be taken into account.

- **Electric barbecues:** the heating is produced because of the heat emitted by large electrical resistances which are heated through the current (it does not mean a combustion of fire).

### 2.2. CLASSIFICATION ACCORDING TO THE INSULATION MEASURES INCORPORATED

#### Traditional Barbecues

- Possibility of assembling the parts on construction site
- Not insulated thermally
- There is not an industrial manufacturer behind them
- There is not a data sheet about the model with maximum temperatures



Prefabricated barbecue (integrated)

#### Prefabricated barbecues (integrated / supported)

- Received at construction site as a whole
- Insulated thermally
- The manufacturer takes responsibility for the solution
- Each industrial model includes maximum temperatures in its technical sheet



Prefabricated barbecue (integrated)



Prefabricated barbecue (supported)

# 3. POSSIBILITIES OF THE USE OF DEKTON AROUND THE BARBECUE

## COMMON USE

- Exterior cladding in front: separated from heat by a refractory wall (resistant to fire action)
- Exterior side cladding; separated from heat by a refractory wall
- Countertop
- Support furniture facing

## SPECIALS

- Interior cladding: generally it is not recommended
- Back front: take into account that flame cannot project against the surface

The following images show the barbecue types and diverse possibilities in which Dekton® can be installed:

### 3.1. TRADITIONAL BARBECUE

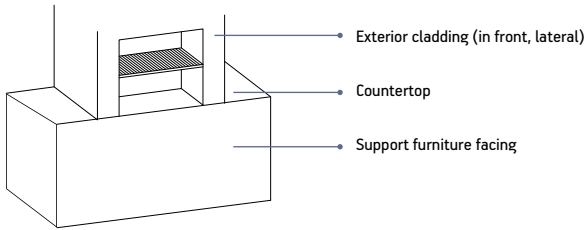

### 3.2. PREFABRICATED BARBECUE (SUPPORTED / INTEGRATED)

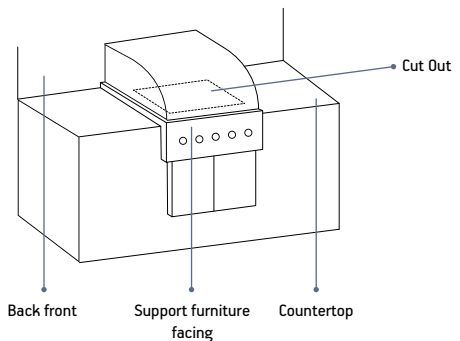
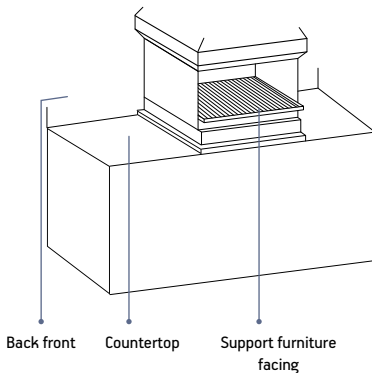

## 4. ASPECTS TO BE CONSIDERED

### 4.1. THERMAL ASPECTS

#### Risks because of extreme heat.

Potential risks depending on heat transmission and barbecue typology:

- Traditional barbecues: high risk of exceeding maximum temperature defined in any point of the surface (direct flame, uncontrollable fire, little space between heat transmitter and material etc.)
- Prefabricated barbecues: low risk of exceeding the maximum temperature defined in any point of the surface (lack of space to expand the material, lack of ventilation, etc.)

#### Particular features according to different uses:

- Tiling. It is necessary to have a separating wall plus isolation so that adhesives can support certain temperature (see supported maximum temperatures). Reinforcement using mechanical fixing.
- Countertops. When the barbecue is on top, it is necessary to have a sufficient ventilated chamber of at least 10 cm between the material and heat transmitter (that it has to be well isolated in all the cases to avoid the emission above 300°C).

### 4.2. OTHER ASPECTS ON WHICH THE BARBECUE CAN INFLUENCE

#### DIMENSIONAL ASPECTS

##### Free expansion.

Metallic materials have higher dilatation than dekonton<sup>®</sup>, so to avoid direct contact, leaving a sufficient space (that will depend on the dimensions of the barbecue, maximum temperature that can be achieved, etc).

#### FABRICATION OF THE COUNTERTOP

- **Interior corners.** Corners must be carefully fabricated, without chippings and with a minimum ratio of 10 mm. Avoid pressure of expanded metal.

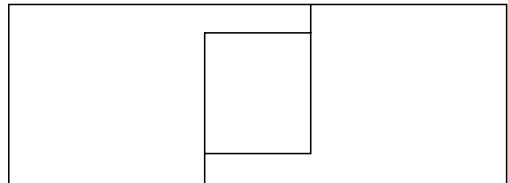
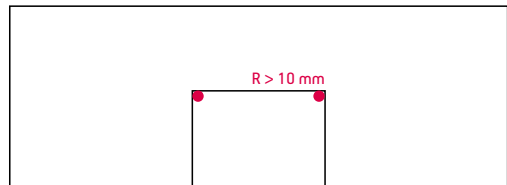

- **Mitred edges.** Mitred edges must be straight from start to finish, without inside corners and changing cut plane (i.E. Of straight mitred edges).

- **Joints.** If worksurface is long and requires more than one piece, joints will be preferably in the cut out leaving a strip in each piece, instead of the two strips in the same piece. This reduces rounded corners from 4 to 2 and reduces possible tensions due to temperature changes.

## INSTALLATION ASPECTS

- **Supports.** The barbecue (especially prefabricated) can have an important weight that needs to be considered if it is supported or embedded in the countertop (i.E. If the weight distribution is transmitted well up to the support or the floor).

- **Base support.** If the structure which supports the barbecue or the countertop is metallic and heats up very fast and/or reaches high temperatures, undesirable effects can be produced (i.E. Tensions in claddings because of the dilation).

## ASPECTS OF USE

- **Hot objects.** Both the grill and the container of the combustible/ coal/ firewood are potential emitters of extreme heat. It is necessary to take precaution when handling.



## 5. PRACTICAL CASES

### 1<sup>ST</sup> CASE: BARBECUE EMBEDDED IN A HOLE WITHOUT ENOUGH SPACE TO DILATE

#### Detected deficiency:

Lack of space to expand (dimensional aspect).

#### Critical aspects:

Metal parts of the grills reach several hundred degrees as they are exposed to the fire and hot coals, expanding centimeters with regard to their size being under room temperature.

#### Good practices:

Leave adequate space between barbecue and countertop.

Place barbecue in the center of the cut out (not having a lot of distance in one side and little in the other)

Take into account that corners are nearer to the barbecue than lateral parts, so they require special attention during the design and the fabrication.



### 2<sup>ND</sup> CASE: BARBECUE ON A COUNTERTOP WITHOUT TAKING INTO ACCOUNT RADIANT EFFECT OF BURNING COALS

#### Detected deficiency:

Uncontrolled radiation of the tray of hot coals against the countertop which is below (thermal aspect).

#### Critical aspects:

The tray of the burning coals can reach the maximum temperature of the fire and coals it has and works as direct radiator against surface below. Lack of ventilation facilitates overheating of air in that space, increasing the final temperature of the surface.

#### Good practices:

Leave a sufficient ventilated facade of at least 10 cm between the material and heat emitter so that the air moves between the material and heat emitter.

Tray must be adequately isolated to prevent uncontrolled temperature peaks above 300 °c.

Make the supports with refractory materials and insulating properties which dissipate excessive heat, so that instead of having an initial excessive heat, it is gradual.

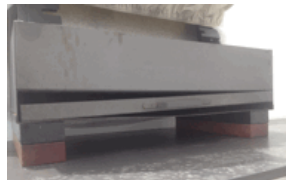
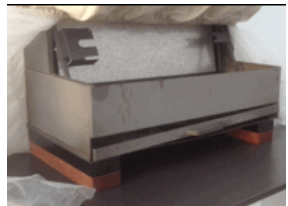

### 3<sup>RD</sup> CASE: BARBECUE WITH INTERIOR CLADDING EXPOSED TO EXTREME CONDITIONS IMPOSSIBLE TO CONTROL

#### Detected deficiency:

Direct exposure to flame and connected radiation phenomena (thermal aspects).

#### Critical aspects:

Flames originated in the barbecue can impact against walls at any time and in an uncontrollable way.

Grills of the barbecue can concentrate heat by conduction (at very high temperature) in points or lines on the surface, with undesirable tensions.

Metal supports can unpredictably expand and contract (because of heat and/or dilation) the material changes cladding.

#### Good practices:

Do not use dektion as interior cladding of homes barbecues.

Use refractory products for that application.

Study with special attention to corners and changes of direction of claddings, anticipating all potential movements of the structure of the barbecue and possible support issues it may have.

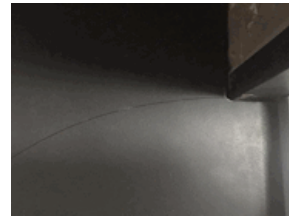

### 4<sup>TH</sup> CASE: BARBECUE POSITIONED INCORRECTLY IN THE CENTER OF THE CUT-OUT AND INCORRECT SUPPORT

#### Detected deficiency:

Excessive pressure due to dilation and incorrect support of the countertop on support (installation aspect).

#### Critical aspects:

Prefabricated barbecue can have a significant weight and the user can place important additional items that carry excessive weight.

During an installation of the prefabricated barbecue, it is essential

to place it in the center of the cut-out. Due to its own weight it will avoid slipping over the countertop when it expands and contracts.

#### Good practices:

Having manufacturer data regarding maximum dilation of the barbecue when operating at maximum temperature, to make a cut-out with larger size.

Identify hot zones during its use (those that can expand more).



The weight of the barbecue must be distributed in a homogeneous way to avoid undesirable mechanical stresses.

The support of the barbecue over the countertop must be leveled and even. The weight to be carried must be supported and transmitted uniformly

## 5<sup>TH</sup> CASE: BARBECUE SUPPORTED OVER INSUFFICIENT SURFACE AND EXPOSED TO RADIANT EFFECT OF BURNING COALS

### Detected deficiency:

Incorrect support of the material (functional aspect) and uncontrolled radiation of the tray of hot coals (thermal aspect).

### Critical aspects:

The weight on the countertop can be heavier than initially thought: weight of the barbecue and everything that can be installed (gas exhaust hood, side supports, combustion material, stones, containers).

During use, dynamic loads which can significantly increase mechanical stresses can be generated.

Burning coal trays concentrate heat in a more aggressively way due to their thickness.

### Good practices:

Dekton can be used as a countertop, but not as a structural element, even less when it can be exposed to temperature and potential impacts (because of dynamic loads and other uncontrollable movements during the use) which could change the stability of the countertop. So it must have a continuous and sufficient support, and the rest of the aspects considered in 2 and 4 cases.



## ANEXO I.

### TYPICAL INSTALLATION OF A PREFABRICATED BARBECUE ON A CONSTRUCTED FURNITURE COVERED WITH DEKTON®

1. Before starting the fabrication of the barbecue, it is necessary to choose its placement properly, taking into account some factors that affect the use of it.



2. After choosing the space in which the barbecue is going to be placed, a sketch of the workspace will be made to ensure a proper measurement.



3. Before the installation of the barbecue, verify that all the material needed is prepared: Tools, materials, adhesive, etc



4. Start the installation of the supporting structure of the barbecue.

Use a specific adhesive for the material in which it is made. It must withstand the heat the barbecue will reach.



5. Once the structure of the barbecue is made, proceed with the placement of Dekton®.

All aspects mentioned in this document and instructions given by the manufacturer of the barbecue must be considered.



## ANEXO II.

### TECHNICAL DATASHEET TYPE OF A PREFABRICATED BARBECUE AND INCLUDED THERMAL ASPECTS

- Dimensions of the structure of the barbecue (important for the cut-out)
- Weight of the barbecue (important for the support)
- Material in which it is made (important for dilation)
- Maximum temperature reached (important for thermal aspects)

<b>EAN</b>	<b>8017709182212</b>
<b>finish</b>	<ul style="list-style-type: none"><li>• AISI 316 Marine Grade stainless steel on all outer surfaces</li><li>• AISI 304 Commercial Grade stainless steel on all cooking surfaces</li></ul>
<b>size</b>	1175W x 545D x 247H
<b>features</b>	<ul style="list-style-type: none"><li>• stainless steel interlocking grill system</li><li>• stainless steel teppanyaki hotplate</li><li>• stainless steel warming rack</li><li>• 5 stainless steel burners</li><li>• laser-etched control panel</li></ul>
<b>thermostat</b>	0-400°C
<b>gas output</b>	NG: 67.5 MJ/hr, 1.0 kPa (over five burners) ULPG: 72.0 MJ/hr, 2.75 kPa (over five burners) Note: barbecue is preset for NG; ULPG conversion kit supplied
<b>standard inclusions</b>	9V battery pack and AC power adaptor
<b>weight</b>	44kg + 12kg hood







---

#### COSENTINO HEADQUARTERS

Ctra. Baza a Huércal - Overa, km 59 / 04850 - Cantoria - Almería (Spain)  
Tel.: +34 950 444 175 / Fax: +34 950 444 226 / [info@cosentino.com](mailto:info@cosentino.com)  
[www.cosentino.com](http://www.cosentino.com) / [www.silestone.com](http://www.silestone.com) / [www.dekton.com](http://www.dekton.com) / [www.scalea.es](http://www.scalea.es)

---

