

# Dekton® 4 & 8 mm Screw fixing on wood

COSENTINO® FAÇADES  
SCREW FIXING ON WOOD





# Index

Objective and scope	4
Screws	5
Drill holes	6
Slab cutting	8
Distance to edge and joints	12
Wood battens recommendations	12
Fixing distances	13
Dekton® installation	14
Accessories	15
System details	16
Health and safety	18

# In this document, Cosentino® sets out basic guidelines for Dekton® 4 mm and 8 mm fixing on wood with screws.

The installation of Dekton® with screw must comply with certain fundamental principles, which will ensure the proper functioning:

- Compliance with the minimum and maximum distances from the fixing to the edge.
- Compliance with the minimum distances for joints.
- Place the screw centred in the hole in the Dekton® tile.
- Install the screw without over-tightening.

## Scope

Dekton® is often used as the external climate screen on ventilated facade construction projects.

Dekton®, as material, does not need to be mounted in direct contact with the air gap in the structure. It is up to the constructor to design the solution when choosing materials and dimensions for the load-bearing structure that Dekton® is mounted onto.

It is regarded standard and a must that the supporting wall in a ventilated facade construction is watertight and the construction shall be able to dry out condensation and/or humidity, by circulating air in the air gap via an inlet in the bottom and an outlet at the top.

In this installation guide, we present the technical instructions for the treatment of Dekton®, installation details, accessories as well as health and safety.

## Screws

Cosentino® recommends screws type TW - S - D16 - 4.8 x 38 mm, Stainless Steel A2, AISI 304 (European standard 1.4567) or similar for fixing Dekton® 4 mm & 8 mm on wood battens.

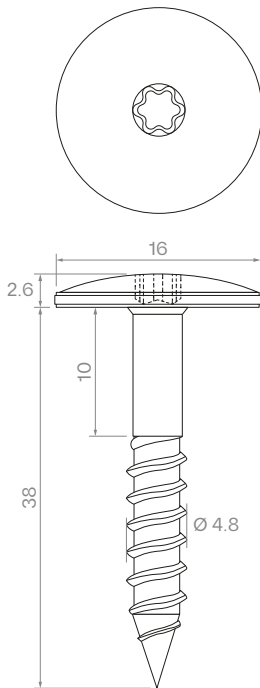

For better integration into the overall appearance of the façade, screws can be lacquered in the Dekton® slab colour.

# Drill holes

- All drill holes in Dekton® are recommended to be done in Ø10 mm.
- Cosentino® can supply Dekton® slabs with the drill holes done according to the assembly drawings.
- In any case, drilling in workshop with CNC machines with water source drilling is advised.
- On-site drilling is also possible for Dekton® 4 mm, both with dry drilling or water-source drilling.
- To avoid chipping, it is recommended to drill on a continuous support of material with a lower density than Dekton® (e.g. wood).

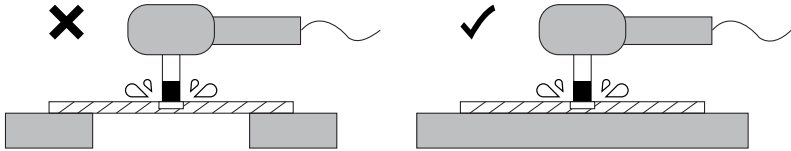

## Recommended drill bits for dry drilling

- Rubi Drygres Ø10 mm for Angle Grinder with M14 Thread or Drill.
- Italdiamant Evogres Ø10 mm for Angle Grinder and CS.08 for Drill.
- ADW Vacuum Ø10 mm for Angle Grinder and CS.08 for Drill.
- POMDI D10 for Angle Grinder.

## Recommended drill bits for water source drilling

- Solestone Ø10 mm with M14 Thread for Angle Grinder.

## Slab cutting

Cosentino® can supply slabs precut according to the assembly drawings.

However, on-site cutting is also possible, with suitable tool and accessories to cut slim slabs as follows:

1. To get a neat cut, the slab must be placed on a stable, flat and sturdy work bench.



2. When making a straight cut, place the cutting guide on the tile along the line to be cut and block it in place with suction cups.



3. Make a small 10 - 20 mm long cut at each end of the tile from the inside towards the outside.



4. Then, complete the cut from one end to the other, making sure you apply the same amount of pressure on the cutting tool for the entire length of the cut.

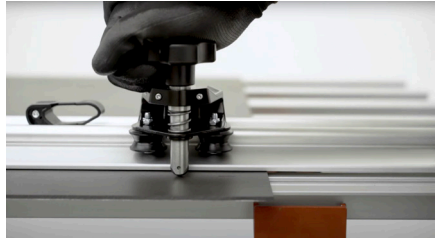

5. Break each end of the tile along the line of the cut with tile snips.



6. The slab is then broken in two by simply bending it until the two pieces come apart.

It is generally recommended to use two people for this operation so that the cut piece doesn't fall or break.

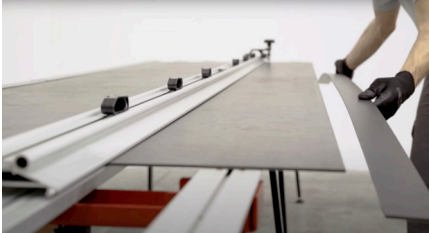

7. Reinforcement mesh in Dekton® can be cut and trimmed with a cutter.



8. If the edges of the tile are sharp or uneven after the previous cut steps, clean and smooth the edges with a diamond pad or an abrasive disc.



9. A straight cut may also be made with a disc cutter which runs along the cutting guide.

A through cut or a partial cut may be made with this method.

In this case, the tile will have a cleaner and better defined edge than by cutting and breaking the slab.





The following blades are recommended for manual cutting:

**ADW Epic**

Available in 115, 125 and 180 mm

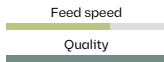
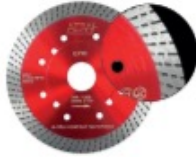

**Italdiamant continuous RIM**

Available in 125 mm

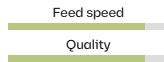

**K&S Red K835**

Available in 115 and 135 mm

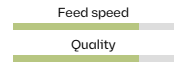
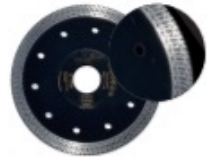

**What are the recommended parameters?**

Diameter of the blade (mm)	115	125	180
Rotation speed* (rpm)	11,000 - 12,000	11,000 - 12,000	11,000 - 12,000

→ (\*) The feed speed should be adjusted according to the type of machine and thickness of the material.  
 → Larger thickness will require reducing the feed speed.

**Requirements of my machine**



Cooling water flow focused on the cutting area



Well-levellbed support



Support the larger dimension of the slab



Sharpen the diamond before each real job



Blade depth 3 to 5 mm on the cutting bed

**Where can I get these tools?**

**AOW**

- a) In the Cosentino® Center of each country.
- b) By the authorized dealer in your area.

**Italdiamant**

- b) By the authorized dealer in your area.

**K&S**

- b) By the authorized dealer in your area.

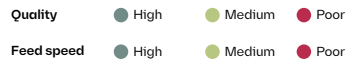

## Distances to edge and joints

- The minimum distance to the edge of the tile shall be 30 mm horizontally and 70 mm vertically.
- The maximum distance from the screw to the edge, in both directions, shall be 100 mm.
- A minimum joint of 5 mm is advised between Dekton® tiles.

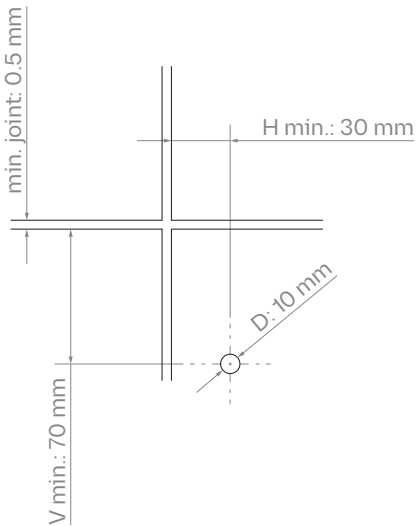

## Wood battens recommendations

- The substrate used has to fulfil local standards and be certified to its use in façade application.
- The substrate must be selected so that the distance from the screw to the edge of the substrate is not less than 15 mm.
- Rubber band or EPDM is needed to protect wood from moisture.

## Fixing distances

- The installer will be responsible for establishing a plumbed and resistant supporting wall able to bear loads appearing on façade according to project conditions.
- The straightness of the substructure may have a maximum tolerance of  $\pm 3$  mm, measured per every two meter.
- Following distances must be observed to fix Dekton®:

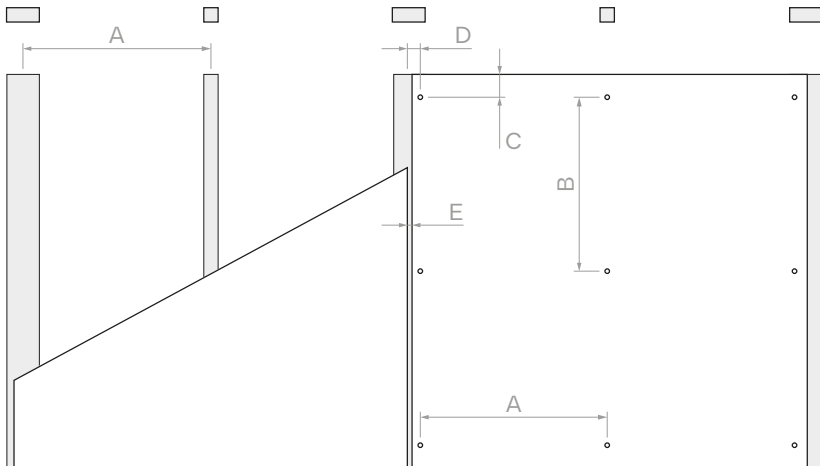

**A. Maximum distance between battens/profiles or horizontal fixings:**

400 mm for Dekton® 4 mm.  
600 mm for Dekton® 8 mm.

**B. Maximum vertical distance between fixings:**

400 mm for Dekton® 4 mm.  
600 mm for Dekton® 8 mm.

**C. Vertical distance to edges:**

between 70 and 100 mm.

**D. Horizontal distance to edges:**

between 30 and 100 mm.

**E. Minimum joint width:**

5 mm.

## Dekton® installation

- The slab can be installed with open joints or with joint profiles.
- When mounting on wood battens, EPDM band shall always be placed on all wood battens in direct contact with the backside of the slab. This is to protect the wood from moisture.
- Once the panel has been drilled according to the established distances between profiles and to the corner, follow the process below to install the slab, properly levelled, in its final position:

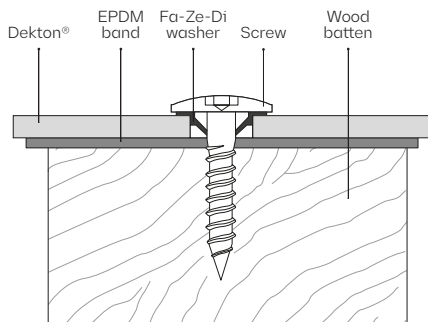

- Screw fixing on wood system detail.

1. Place the Fa-Ze-Di washer inside the drill of the Dekton® tile.

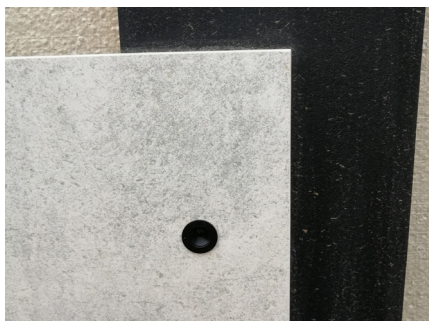

2. Screw the fastener using the provided bit.

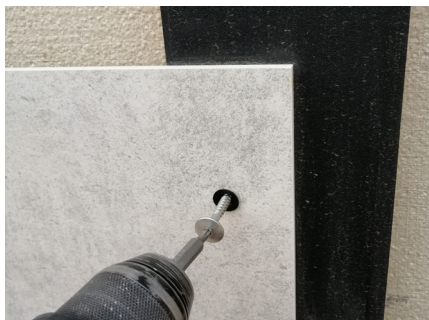

3. Tight the screw till the head contacts the Fa-Ze-Di washer.



- Regardless of the slab size, place two fixed points per slab.
- For Dekton® 4 mm, these fix points include sleeves of  $\text{Ø}9.5 \times 3.5 - 5.1 \text{ mm}$  and, for Dekton® 8 mm, sleeves of  $\text{Ø}9.5 \times 7.4 - 5.1 \text{ mm}$ .
- Fix points are placed aligned in horizontal in a centred position in the slab and with same criteria in slabs situated in same line (e.g. centre - right).

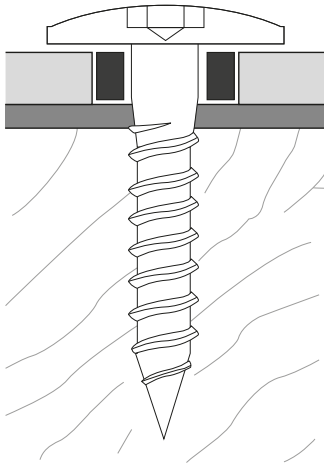

→ Fix point - Dekton® 4 mm.

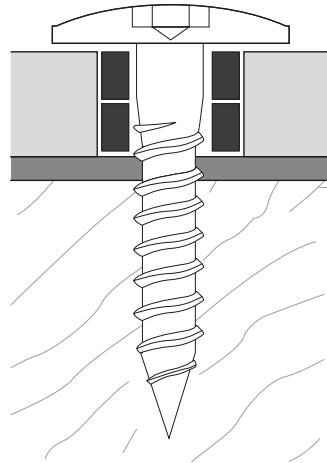

→ Fix point - Dekton® 8 mm.

### Examples of correct positioning of fixed points

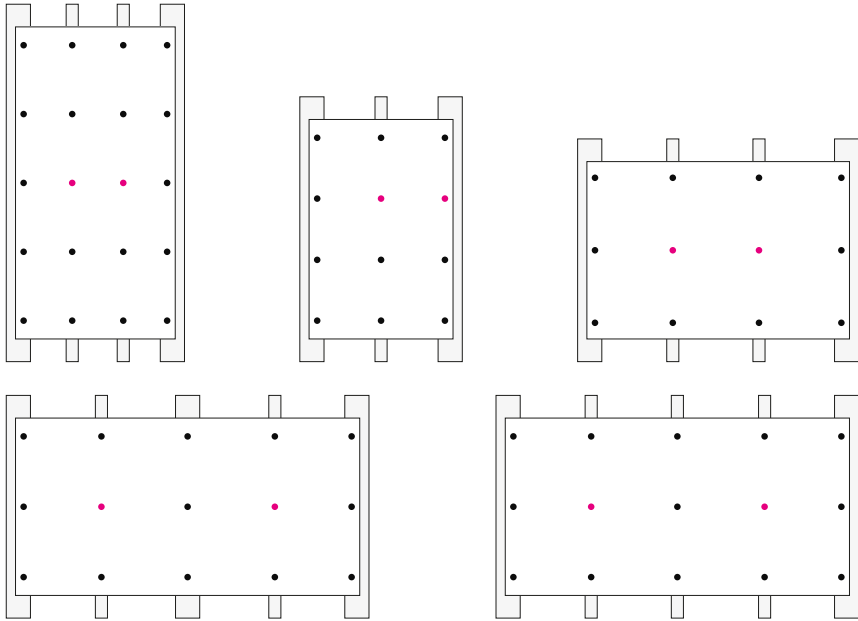

### Examples of incorrect positioning of fixed points

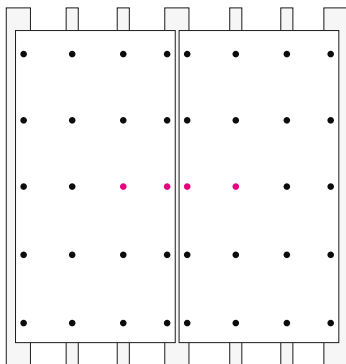

#### Key

- Sliding points
- Fixed points

# Accessories

Following accessories can be applied together with Dekton® 4 mm and 8 mm:

- Screw TW S Ø16 4.8 x 38 mm.
- Fa-Ze-Di washer.
- Inox sleeve of Ø9.5 x 3.5 - 5.1 mm for Dekton® 4mm and Ø9.5 x 7.4 - 5.1 mm for Dekton® 8 mm.
- EPDM band 70 mm / 110 mm.

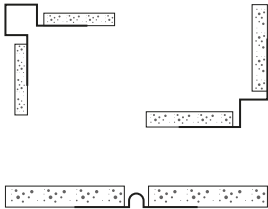

→ Indoor/outdoor corner profiles, joint profiles.

→ EPDM or Rubber between Dekton® and wood battens.

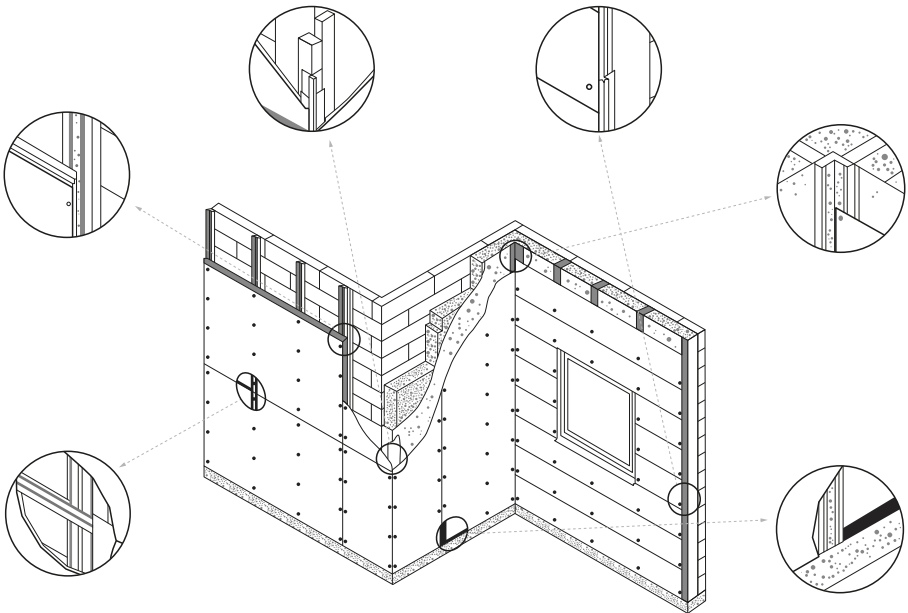

# System details

## Vertical section

Bottom detail

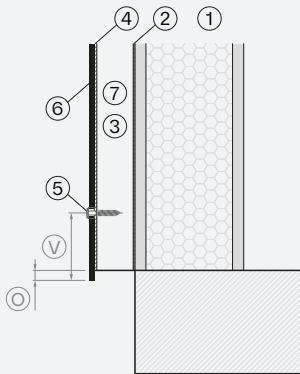

Upper detail

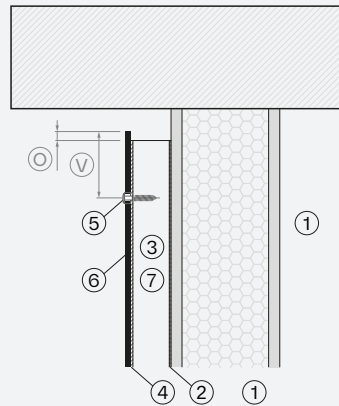

Horizontal joint

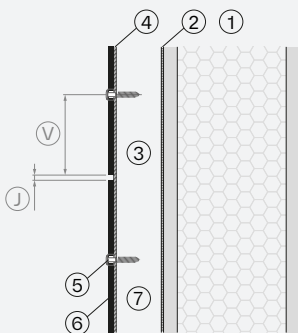

1. Supporting wall  
2. Wind barrier  
3. Wood batten  
4. EPDM band

5. Screw  
6. Dekton® Protek  
7. Air chamber

H. Horizontal edge  
distance (30 - 100 mm)  
V. Vertical edge  
distance (70 - 100 mm)

O. Overhang (10 mm)  
J. Joint width (5 mm)



## Horizontal section

External corner

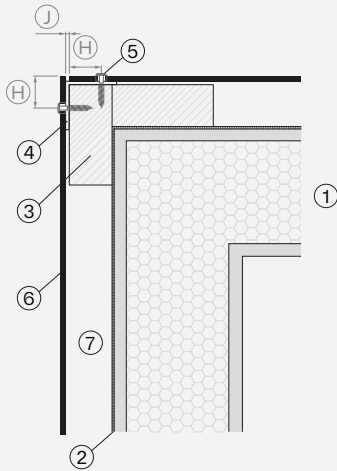

Internal corner

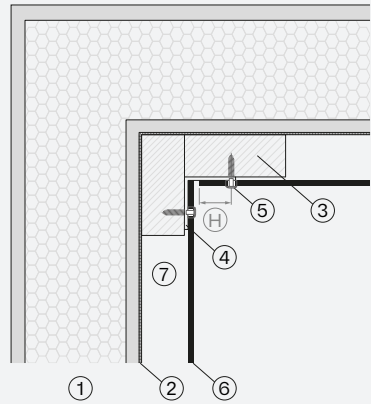

Vertical joint

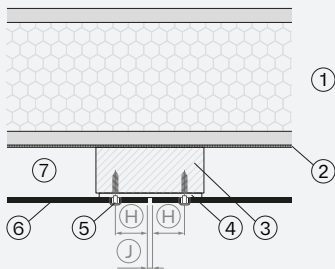

- 1. Supporting wall
- 2. Wind barrier
- 3. Wood batten
- 4. EPDM band

- 5. Screw
- 6. Dekton® Proték
- 7. Air chamber

- H. Horizontal edge distance (30 - 100 mm)
- V. Vertical edge distance (70 - 100 mm)

- O. Overhang (10 mm)
- J. Joint width (5 mm)

# Health and safety

## Risks associated with handling and transport

Operators and fitters dealing with Dekton® must comply with all laws and regulations relating to occupational health and safety in workplaces, as well as the information contained in this Guide.

During transport and handling of Dekton® materials, risks such as bumps, cuts, musculoskeletal disorders, entrapment or blast injuries can occur due to incorrect handling.

Always follow the safety instructions contained in this Guide.

## Risks associated with manufacturing and transformation

The manufacturing process can involve risks such as cuts, blast injuries, entrapment, exposure to high noise levels and exposure to chemicals such as free crystalline silica dust.

For more information about these risks and measures to prevent them, consult the Safety Information Sheet as well as the Best Practice Guide that Cosentino® has published.

If you do not have this information, please ask your supplier.

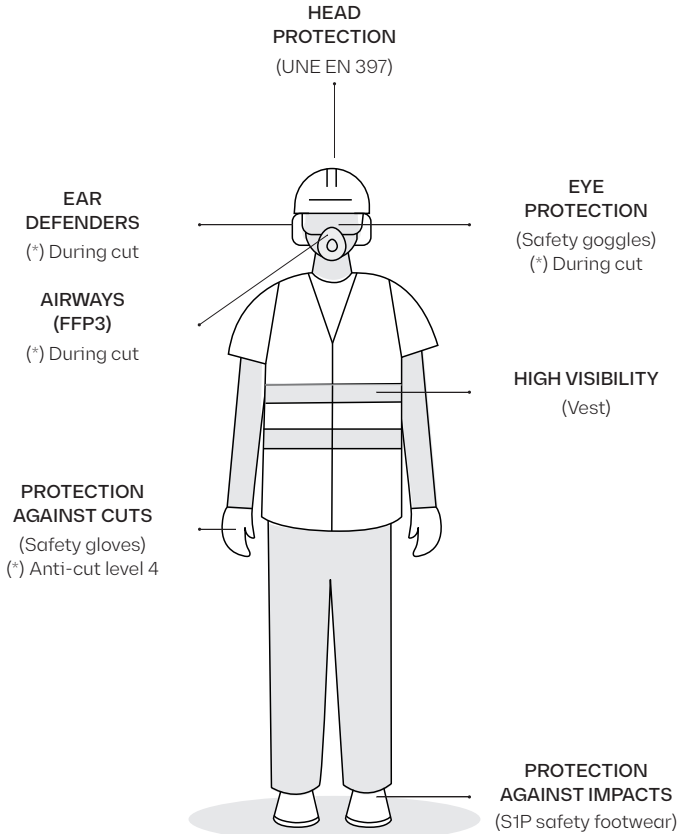





## COSENTINO®

Ctra. Baza a Huerca-Overa, km 59 / 04850  
Cantoria - Almeria (Spain) / Tel.: +34 950 444 175  
info@cosentino.com / www.cosentino.com



(\*) Find information on NSF-certified colours at [www.nsf.org](http://www.nsf.org)

REV. 01 - 10/2022